



HSAC

Helicopter Safety Advisory Conference

Safety Through Cooperation
Since 1978

Aerial Observation Committee Summary

Winston Seiler

(661) 333-6036

winston@kcsiaerialpatrol.com

Agenda

AOPA Air Safety Institute

Avguard Light Update

Safety, Incident Reporting, and Shares

PHMSA Regulation Update

Part 108 Discussion

Other Items/January Meeting Planning

Paul Deres

W. Seiler

W. Seiler/T. Buchner

All

P. Smith

All

20 Participants: Aerial Patrol, LLC, Barr, Energy Transfer, KCSI Aerial Patrol, Chevron, Shell, Hawkeye/Avco, Legacy Air One, American Patrols, Airborne Energy Solutions, CB Helos



airsafetyinstitute.org

MODERN CHANNELS

EXPANDING REACH THROUGH SOCIAL MEDIA AND YOUTUBE TO INFLUENCE PILOT BEHAVIOR AND DECISIONS

INSIGHTFUL ANALYSIS

RICHARD McSPADDEN REPORT, SEAPLANE ACCIDENTS, NIGHT FLYING, FLIGHT TRAINING ACCIDENTS, AND MORE

INDUSTRY LEADERSHIP

GENERAL AVIATION JOINT SAFETY COMMITTEE AND NUMEROUS SUB-COMMITTEES

May 2026, Mental Health Awareness Campaign

CFI RENEWALS

AWARD-WINNING CFI REFRESHER COURSE
ENGAGING CONTENT
100% REVENUE BACK INTO SAFETY PROGRAMS

OUTREACH AND EVENTS

IN-PERSON SEMINAR AND KEYNOTE PRESENTATIONS AT AVIATION EVENTS, UNIVERSITIES, PILOT ASSOCIATIONS

FOCUSED FLIGHT REVIEW

SIX UNIQUE PROFILES:
POSITIVE AIRCRAFT CONTROL, IFR, BEYOND THE BASICS, BACKCOUNTRY, SEAPLANES, HELICOPTER

ONLINE RESOURCES

250+ VIDEOS, 30 PUBLICATIONS, 13 ONLINE COURSES, 60 SAFETY QUIZZES, AND MORE!



HSAC

Helicopter Safety Advisory Conference

Safety Through Cooperation
Since 1978

Lite Enterprises AvGuardian Bird Strike Deterrence

- Light Emissions: complex pulsating patterns of ultraviolet light of ultraviolet light
- Increase flight path separation is field proven
- Attention/aware (4th color cone) \approx 99% of avian species
- Humans is considered not 'visible'
- Operation and installation is simple
- Device Operation (ON/OFF) is Pilot's decision
- NORSEE Approved for Part 23 Aircraft below 12,500 lbs

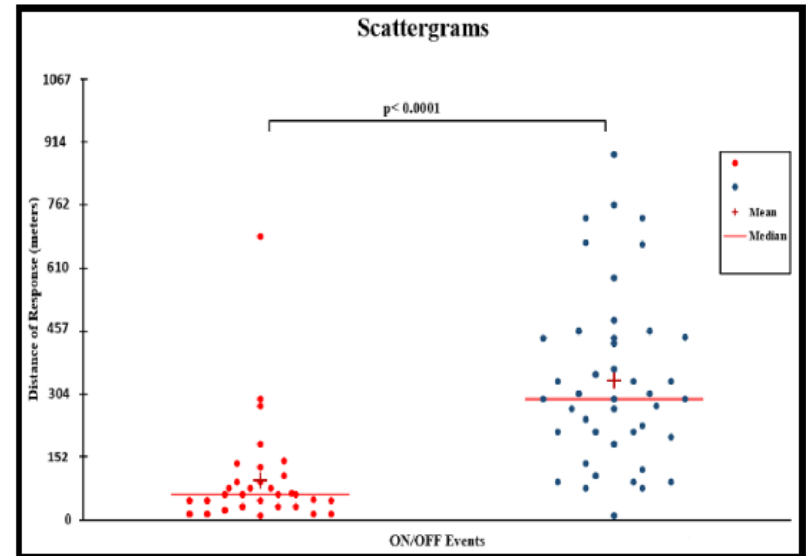
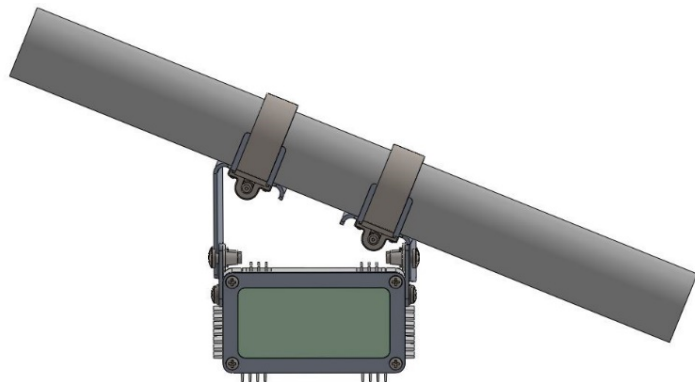

Figure 9. Scattergram illustrating birds' reaction distance to plane with *PAR46_{UVLED}* for *ON* vs *OFF*



**From 8-10 Bird Strikes
Per Season to None!**
FAA NORSEE Approved





HSAC

Helicopter Safety Advisory Conference

Safety Through Cooperation
Since 1978

Safety, Incident Reporting and Shares

- 2025 Incident and Accident Review: Notable Events
- Voluntary Safety Shares:
 - Violation of Vice Presidential TFR – Pilot was aware beforehand, but got caught up in the normal routine of the patrol. Recommended having a secondary reminder of the abnormal condition: post it, alarm at approx. time on site, Foreflight use.
 - Rags Left in Helicopter after Maintenance – Rags were the similar color as the helicopter interior and was left by maintenance at a change in task. Recommended only using rags of a bright, high contrast color
 - Value of slowing down during preflight activities – attention during repetitive tasks for incident prevention

Safety Performance GA Accident Rate:

Accidents Per 100,000 Flight Hours, 1990-2022

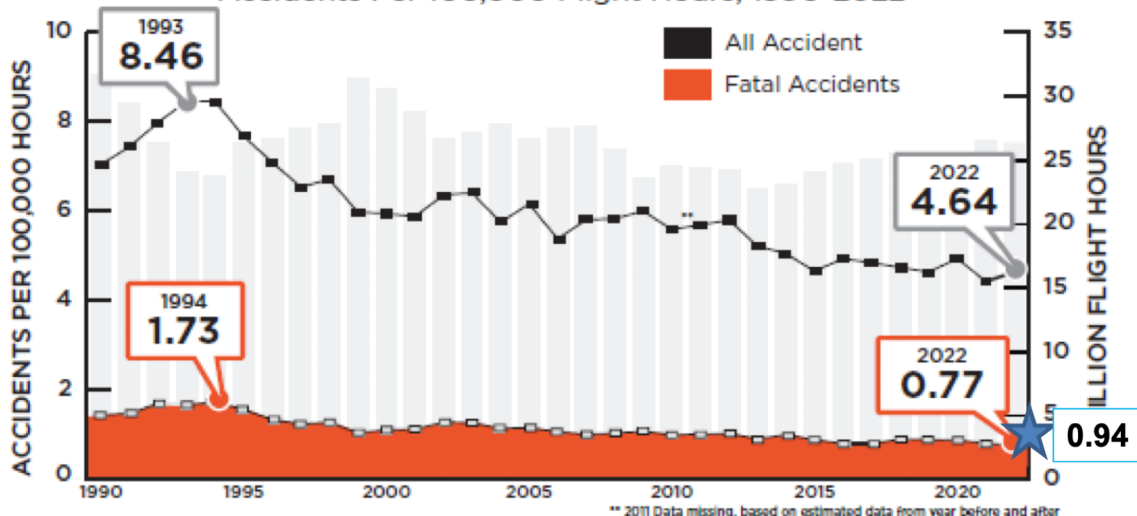

1950 47 accidents/100,000 flight hrs

2022 GA 4.64/100K hrs

2023 Aerial Patrol ~3/100K

2023 HSAC Participants 0.94/100K



HSAC

Helicopter Safety Advisory Conference

Safety Through Cooperation
Since 1978

Updates to PHMSA Regulation Effective Today (10/9/2025)

PART 192—TRANSPORTATION OF NATURAL AND OTHER GAS BY PIPELINE: MINIMUM FEDERAL SAFETY STANDARDS

- 1. The authority citation for 49 CFR part 192 continues to read as follows

Authority: 30 U.S.C. 185(w)(3), 49 U.S.C. 5103, 60101 *et seq.*, and 49 CFR 1.97.

- 2. Revise § 192.705(c) to read as follows

§ 192.705 Transmission lines: Patrolling.

* * * * *

(c) Methods of patrolling include walking, driving, flying via manned or unmanned aerial systems, imaging via satellite, or other means suitable for observing current surface conditions.

PART 195—TRANSPORTATION OF HAZARDOUS LIQUIDS BY PIPELINE

- 3. The authority citation for part 195 continues to read as follows:

Authority: 30 U.S.C. 185(w)(3), 49 U.S.C. 5121, 60101 *et seq.*, and 49 CFR 1.97.

- 4. Revise § 195.412(a) to read as follows

§ 195.412 Inspection of rights-of-way and crossings under navigable waters.

(a) Each operator shall, at intervals not exceeding 3 weeks, but at least 26 times each calendar year, inspect the surface conditions on or adjacent to each pipeline right-of-way. Methods of inspection include walking, driving, flying via manned or unmanned aerial systems, imaging via satellite, or other means suitable for observing current surface conditions.

* * * * *



HSAC

Helicopter Safety Advisory Conference

Safety Through Cooperation
Since 1978

Part 108 Update and Discussion

- Applies to BVLOS flights below 400 ft AGL (or within shielded area)
- 731 pages long regulatory document
- Enables missions like “delivery” ag, survey, public safety, and recreation
- To be published in 2026Q1, but hypothesized that there will be several more rounds of comments, with actual implementation at the end of 2026. But the official date is 2026Q1
- Likely to have impacts to manned operations once implemented
- Likely to have impact to manned aircraft long distance pipeline patrol services in the coming future at a time to be determined, but in the foreseeable future.
- Phil Smith and the UAS Working Group for More Information.



HSAC

Helicopter Safety Advisory Conference

Safety Through Cooperation
Since 1978

January 14, 2025 Meeting in Houston

- Preferred Guest Speaker: National Rescue Command Center – What happens when an ELT is activated and how can pilots get rescued as quickly as possible
- Preferred Guest Speaker: IOGP Update from De Jansen
- Four new participants in this meeting, will be reaching out to them to determine what content will get them to come to the next meeting and ongoing participation

- Aerial Patrol, LLC
- Aero Plus
- Airborne Energy Solutions (Canada)
- Aircraft Data
- American Patrols
- Aviation Specialists
- Barr Air Patrol
- Brentco Aerial Patrol
- CB Helos
- Eagle Sky Patrol
- Enbridge Pipeline
- Energy Transfer
- Falcon Aviation
- Guardian Aerial Patrol
- Hawkeye Helicopter
- INR Inspection Services
- KCSI Aerial Patrol
- Kenai Aviation
- Kenan Aviation
- Legacy Air One
- Midwest Avtech
- Revelator Services
- Reynold's Aviation
- Skywatch Aerial Patrol
- TAF Aerial Inspections
- Texas Aerial Inspections
- TransCanada
- Western Edge
- Westwind Helicopters